

NEW!

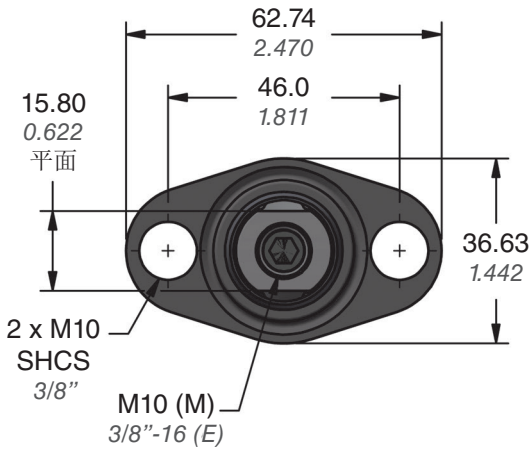

导柱行程 编码	*XS		PL		导柱行程 编码	*XS		PL	
	mm	inch	mm	inch		mm	inch	mm	inch
0200	20.0	0.787	47.0	1.850	0254	25.4	1.000	52.40	2.063
0300	30.0	1.181	57.0	2.244	0318	31.75	1.250	58.75	2.313
0350	35.0	1.378	62.0	2.441	0381	38.1	1.500	65.10	2.563
0400	40.0	1.575	67.0	2.638	0445	44.45	1.750	71.45	2.813
0450	45.0	1.772	72.0	2.835	0508	50.8	2.000	77.80	3.063
0500	50.0	1.969	77.0	3.032	0572	57.15	2.250	84.15	3.313
0550	55.0	2.165	82.0	3.228	0635	63.5	2.500	90.50	3.563
0600	60.0	2.362	87.0	3.425	0699	69.85	2.750	96.85	3.813
0700	70.0	2.756	97.0	3.819	0762	76.2	3.000	103.20	4.063
0750	75.0	2.953	102.0	4.016	0826	82.55	3.250	109.55	4.313
0800	80.0	3.150	107.0	4.213	0889	88.9	3.500	115.90	4.563

*XS = PL - GRL
导套长度 (GRL) = 27.00 mm (1.063 in)

速度估算	(m/sec)	0.50	0.60	0.70	0.80	0.90	1.00	1.10	1.20
每个GRS	max (lb.)	35	24	18	14	11	9	7	6
	max (kg)	16	11	8	6	5	4	3	3

垫板重量	kg	GRS.20.HD1 数量							
		lb.	kg	lb.	kg	lb.	kg	lb.	kg
5	2	2	2	2	2	2	2	2	2
10	5	2	2	2	2	2	3	3	3
20	9	2	2	3	3	3	4	4	5
30	14	2	3	3	4	4	5	6	6
40	18	3	3	4	4	5	6	7	8
50	23	3	4	4	5	6	7		
70	32	3	4	5	7	8			
90	41	4	5	7	8				

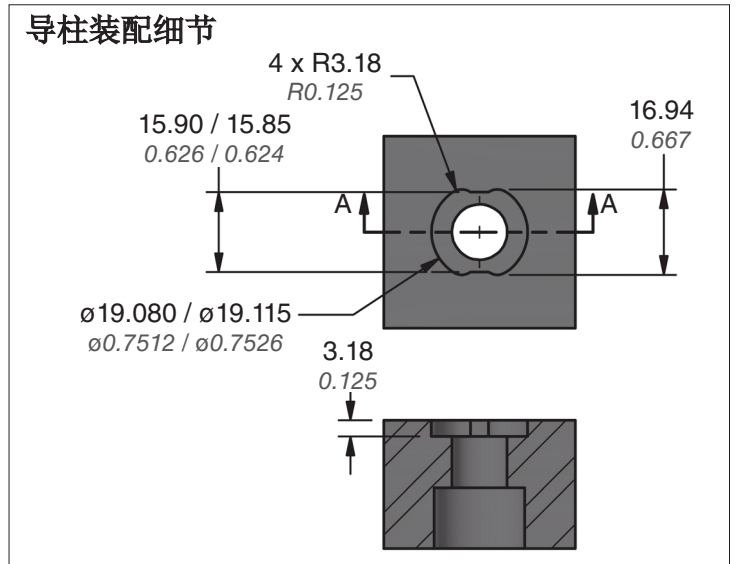
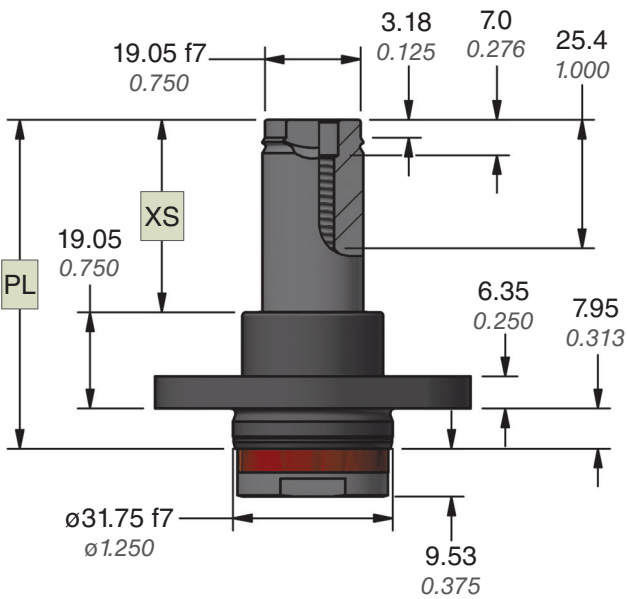

订购示例:

GRS.20.HD1. M. 0500

产品型号: _____
包括系列, 导柱直径和导套安装类型

导柱行程: 0200 - 0889
例子: 0500 = 50.0 mm = XS 尺寸

导柱选项: _____
M = M10, 公制;
E = 3/8" - 16, 英制

GRS.20.HD2

NEW!

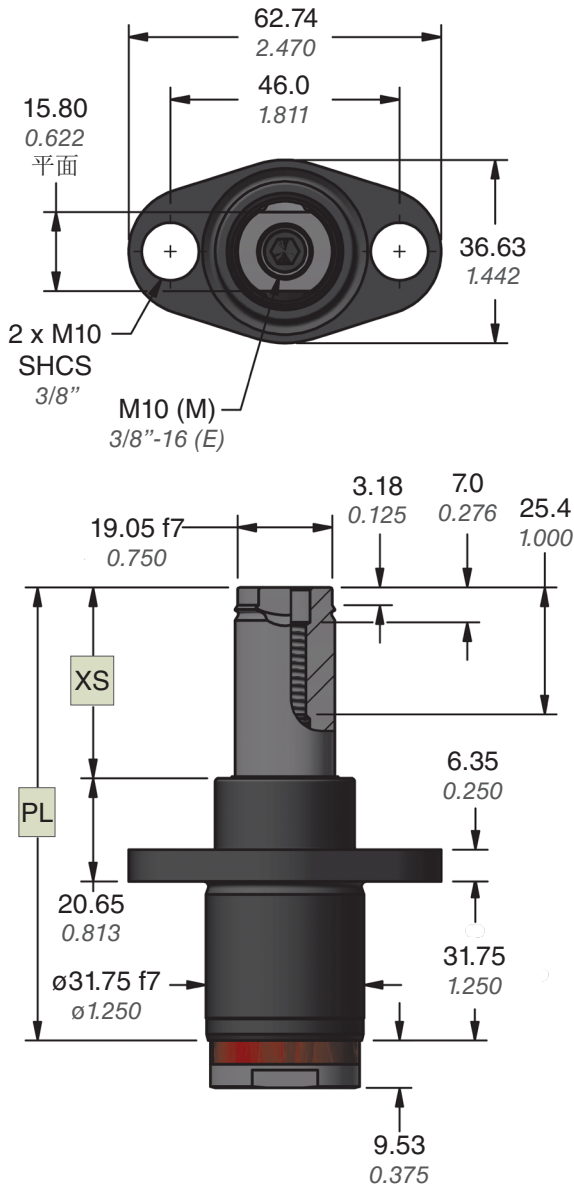

导柱行程 编码	*XS		PL		导柱行程 编码	*XS		PL	
	mm	inch	mm	inch		mm	inch	mm	inch
0200	20.0	0.787	72.4	2.850	0254	25.4	1.000	77.80	3.063
0300	30.0	1.181	82.4	3.244	0318	31.75	1.250	84.15	3.313
0400	40.0	1.575	92.4	3.638	0381	38.1	1.500	90.50	3.563
0500	50.0	1.969	102.4	4.031	0445	44.45	1.750	96.85	3.813
0550	55.0	2.165	107.4	4.228	0508	50.8	2.000	103.20	4.063
0600	60.0	2.362	112.4	4.425	0572	57.15	2.250	109.55	4.313
0700	70.0	2.756	122.4	4.819	0635	63.5	2.500	115.90	4.563
0750	75.0	2.953	127.4	5.016	0699	69.85	2.750	122.25	4.813
0800	80.0	3.150	132.4	5.213	0762	76.2	3.000	128.60	5.063
0900	90.0	3.543	142.4	5.606	0826	82.55	3.250	134.95	5.313
0950	95.0	3.740	147.4	5.803	0889	88.9	3.500	141.30	5.563
1000	100.0	3.937	152.4	6.000	0953	95.25	3.750	147.65	5.813
1100	110.0	4.331	162.4	6.394	1016	101.6	4.000	154.00	6.063
1200	120.0	4.724	172.4	6.787	1143	114.3	4.500	166.70	6.563
1300	130.0	5.118	182.4	7.181	1270	127.0	5.000	179.40	7.063
1400	140.0	5.512	192.4	7.575	1397	139.7	5.500	192.10	7.563
1500	150.0	5.906	202.4	7.969	1524	152.4	6.000	204.80	8.063

*XS = PL - GRL
导套长度 (GRL) = 52.40 mm (2.063 in)

速度估算 (m/sec)	0.50	0.60	0.70	0.80	0.90	1.00	1.10	1.20	
每个GRS	max (lb.)	35	24	18	14	11	9	7	6
	max (kg)	16	11	8	6	5	4	3	3

垫板重量	GRS.20.HD2 数量									
	lb.	kg	2	2	2	2	2	2	2	2
5	2	2	2	2	2	2	2	2	2	2
10	5	2	2	2	2	2	3	3	3	3
20	9	2	2	3	3	3	4	4	4	5
30	14	2	3	3	4	4	5	6	6	6
40	18	3	3	4	4	5	6	7	8	
50	23	3	4	4	5	6	7			
70	32	3	4	5	7	8				
90	41	4	5	7	8					

导柱装配细节

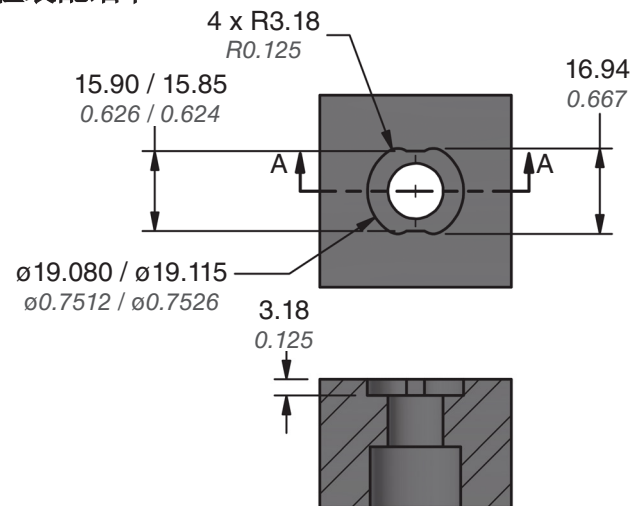

订购示例:

GRS.20.HD2. M. 0500

产品型号: _____
包括系列, 导柱直径和导套安装类型

导柱行程: 0200 - 1524
例子: 0500 = 50.0 mm = XS 尺寸

导柱选项: _____
M = M10, 公制;
E = 3/8" - 16, 英制